



WESTMINSTER  
SCHOOL

## **The Challenge (Core)**

Specimen Paper First Examination 2027

# **MATHEMATICS**

Time: 60 minutes

**Instructions to candidates:**

- You will need a calculator for this paper.
- All your working should be clearly shown.
- You should attempt all the questions.
- Please write in black or blue ink.
- Write your answers in the answer booklet provided.

- 1 Solve the following simultaneous equations.

$$\begin{aligned}y &= 2x - 3y + 1 \\ y &= 2(3x - 1)\end{aligned}$$

- 2 Fifteen clippers will make a total of 19.8 million paperclips in exactly two hours. How long will it take fourteen clippers to make 53.9 million paperclips?
- 3 How long, in hours and minutes, does it take to run 26.2 miles at 3.33 metres per second?

[Conversion: 1 mile = 1609 metres.]

- 4 a Make  $y$  the subject of  $\frac{a}{by} = b$

b i Simplify  $\frac{3}{4}(2 - 3x) - \frac{1}{4}x + \frac{5}{4}$

ii Solve  $\frac{3}{4}(2 - 3x) - \frac{1}{4}x + \frac{5}{4} = 26$

- 5 The diagram shows a parallelogram with area  $8164.8 \text{ mm}^2$ . Find the shaded area.

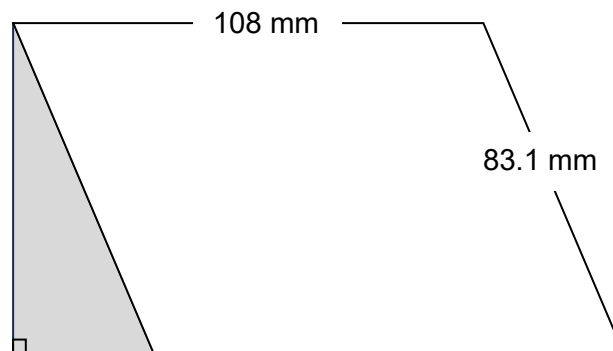

- 6 Big Ben is at latitude 51.5007 degrees North (of the equator) and longitude 0.1246 degrees West (of the Greenwich Meridian). Erith Town Football Club's stadium is at latitude 51.5055 degrees North and longitude 0.1306 degrees East.

The Millennium Dome is exactly halfway between Big Ben and Erith Town Football Club's stadium. Find the latitude and longitude of the Millennium Dome.

- 7 The organiser of the European Solitaire Championships opens a large number of boxes of marbles, each containing exactly 100, and tips them into an empty barrel.

Each Solitaire board requires 36 marbles. She sets out as many complete Solitaire boards as possible. She finds that there are exactly 4 marbles left in the barrel.

Given that she opened more than 200 boxes of marbles, what is the smallest possible number of boards she could have set out?

- 8 a Farmer Jack has a barn full of carrots. Each week, he eats  $15\frac{1}{2}\%$  of the carrots which remained in his barn at the start of that week. What percentage of the original quantity of carrots is left at the end of the fifteenth week?
- b Farmer Dave has a barn full of parsnips. Each week, he eats  $n\%$  of the parsnips which remained in his barn at the start of that week. By the end of the fourth week, he has eaten 58% of the original quantity of parsnips. Find  $n$ .
- 9 Uncle Seán's pepperoni pizzas have a diameter of 10 inches. A  $45^\circ$  slice costs £3.45. Geronimo's sells pepperoni pizzas in square slices costing £4 each. Uncle Seán's pizza is 10% cheaper per square inch.

What is the side length in inches of the slices at Geronimo's?

- 10 You are driving along a two-way road with one lane of traffic in each direction. Your lane of traffic is moving at a constant speed of 40 miles per hour and the opposing traffic is moving at a constant speed of 50 miles per hour. Every 1.05 seconds, you pass a car travelling in the opposite direction.

The *Highway Code* advises drivers to "allow at least a two-second gap between you and the vehicle in front". Are the opposing drivers following this rule? Show how you decided.

- 11 The diagram shows a semicircle and an isosceles triangle.

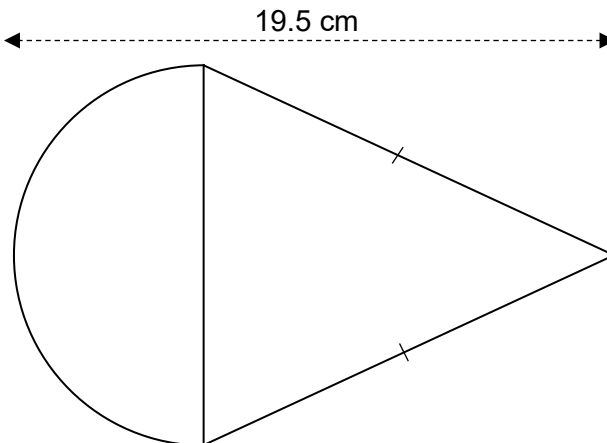

The ratio area of semicircle : area of triangle is 2 : 3.  
What is the external perimeter of the figure?

**END OF QUESTIONS**

## ANSWERS

- 1 Solve the following simultaneous equations.

$$\begin{aligned}y &= 2x - 3y + 1 \\ y &= 2(3x - 1)\end{aligned}$$

$$4y = 2x + 1 \text{ and } 4y = 24x - 8$$

$$x = \frac{9}{22} \text{ and } y = \frac{5}{11}$$

- 2 Fifteen clippers will make a total of 19.8 million paperclips in exactly two hours. How long will it take fourteen clippers to make 53.9 million paperclips?

$$2 \times \frac{15}{14} \times \frac{53.9}{19.8}$$

$$5\frac{5}{6} \text{ hours} = 5 \text{ hours } 50 \text{ minutes}$$

- 3 How long, in hours and minutes, does it take to run 26.2 miles at 3.33 metres per second?

[Conversion: 1 mile = 1609 metres.]

$$\frac{26.2 \times 1609}{3.33} \text{ seconds; divide by } 60^2 \text{ to get } 3.516 \text{ hours.}$$

About 3 hours and 31 minutes.

- 4 a Make  $y$  the subject of  $\frac{a}{by} = b$

$$y = \frac{a}{b^2}$$

b i Simplify  $\frac{3}{4}(2 - 3x) - \frac{1}{4}x + \frac{5}{4}$

$$-\frac{5}{2}x + \frac{11}{4}$$

ii Solve  $\frac{3}{4}(2 - 3x) - \frac{1}{4}x + \frac{5}{4} = 26$

$$x = -9.3$$

- 5 The diagram shows a parallelogram with area  $8164.8 \text{ mm}^2$ . Find the shaded area.

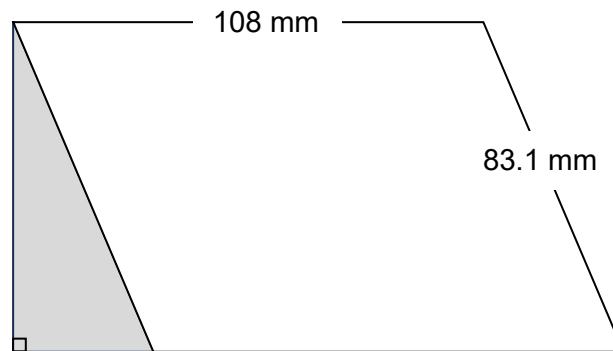

The perpendicular height of the parallelogram is  $\frac{8164.8}{108} = 75.6 \text{ mm}$ .

So the base of the triangle is  $\sqrt{83.1^2 - 75.6^2} = 34.5 \text{ mm}$ .

The shaded area is  $\frac{1}{2} \times 34.5 \times 75.6 = 1304.1 \text{ mm}^2$ .

- 6 Big Ben is at latitude  $51.5007$  degrees North (of the equator) and longitude  $0.1246$  degrees West (of the Greenwich Meridian). Erith Town Football Club's stadium is at latitude  $51.5055$  degrees North and longitude  $0.1306$  degrees East.

The Millennium Dome is exactly halfway between Big Ben and Erith Town Football Club's stadium. Find the latitude and longitude of the Millennium Dome.

Treat East as positive and West as negative (as in conventional coordinates).

Then the Millennium Dome's latitude is  $\frac{51.5007+51.5055}{2} = 51.5031$  degrees North, and its longitude is  $\frac{-0.1246+0.1306}{2} = 0.0030$  degrees East.

- 7 The organiser of the European Solitaire Championships opens a large number of boxes of marbles, each containing exactly 100, and tips them into an empty barrel.

Each Solitaire board requires 36 marbles. She sets out as many complete Solitaire boards as possible. She finds that there are exactly 4 marbles left in the barrel.

Given that she opened more than 200 boxes of marbles, what is the smallest possible number of boards she could have set out?

Suppose she opens  $n$  boxes and sets out  $x$  boards.

$$100n = 36x + 4$$

Trial and error for  $n = 200, 201, \dots$  yields  $x = 561$  as the smallest possible value of  $x$ .

- 8 a Farmer Jack has a barn full of carrots. Each week, he eats  $15\frac{1}{2}\%$  of the carrots which remained in his barn at the start of that week. What percentage of the original quantity of carrots is left at the end of the fifteenth week?

$$0.845^{15} = 0.08 \text{ so } 8\%$$

- b Farmer Dave has a barn full of parsnips. Each week, he eats  $n\%$  of the parsnips which remained in his barn at the start of that week. By the end of the fourth week, he has eaten 58% of the original quantity of parsnips. Find  $n$ .

Let the weekly scale factor on the number remaining be  $f$ .

$$f^4 = 0.42 \text{ so } f = 0.805 \text{ so } n = 19\frac{1}{2}.$$

*[There is a question of this type in the Challenge almost every year: candidates would be well advised to learn how to tackle them.]*

- 9 Uncle Seán's pepperoni pizzas have a diameter of 10 inches. A  $45^\circ$  slice costs £3.45. Geronimo's sells pepperoni pizzas in square slices costing £4 each. Uncle Seán's pizza is 10% cheaper per square inch.

What is the side length in inches of the slices at Geronimo's?

$$\text{Uncle Seán's } \text{£ per square inch} = \frac{3.45}{\frac{1}{8}\pi \times 5^2}, \text{ whereas Geronimo's } \text{£ per square inch} = \frac{4}{x^2}$$

$$\frac{4}{x^2} \times 0.9 = \frac{3.45}{\frac{1}{8}\pi \times 5^2}$$

$$x = 3.2 \text{ [inches]}$$

- 10 You are driving along a two-way road with one lane of traffic in each direction. Your lane of traffic is moving at a constant speed of 40 miles per hour and the opposing traffic is moving at a constant speed of 50 miles per hour. Every 1.05 seconds, you pass a car travelling in the opposite direction.

The *Highway Code* advises drivers to "allow at least a two-second gap between you and the vehicle in front". Are the opposing drivers following this rule? Show how you decided.

The closing speed is 90 mph, so the gap between successive opposing vehicles is

$$90 \times \frac{1.05}{60^2} = 0.02625 \text{ miles.}$$

Opposing drivers cover this distance in  $\frac{0.02625}{50} \times 60^2 = 1.89$  seconds, so no, opposing drivers are not following the rule.

- 11 The diagram shows a semicircle and an isosceles triangle.

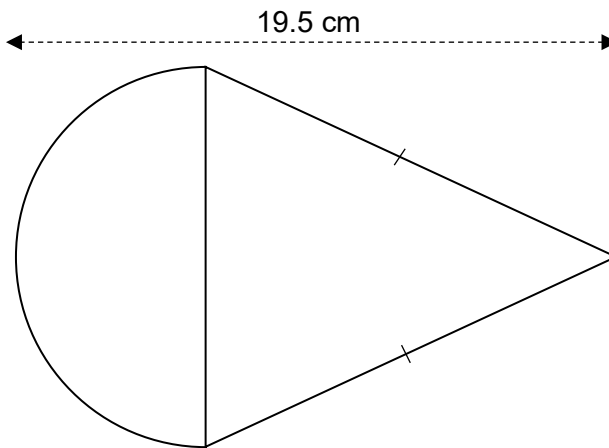

The ratio area of semicircle : area of triangle is 2 : 3.  
What is the external perimeter of the figure?

Let the radius of the semicircle be  $r$  cm.

$$\frac{\frac{1}{2}\pi r^2}{\frac{1}{2}(2r)(19.5-r)} = \frac{2}{3}$$

$$3\pi r = 78 - 4r$$

$$r(3\pi + 4) = 78$$

$$r = \frac{78}{3\pi+4}$$

$$\text{Perimeter} = \pi r + 2\sqrt{r^2 + (19.5 - r)^2} = 48 \text{ cm}$$

**END OF QUESTIONS**